

Power Electronics

Measurements and solutions

Jean-François Braud
Rohde & Schwarz France
Product Support Engineer for oscilloscope

Power Electronics Is everywhere

Computer electronics



Automotive (here, Tesla)



Bluetooth low energy beacon



Mobile phones /
wearables



Solar Inverter



Tooling



Power Electronics Converter Type

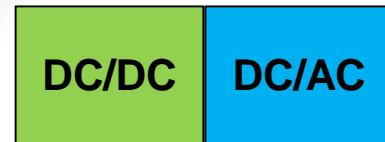
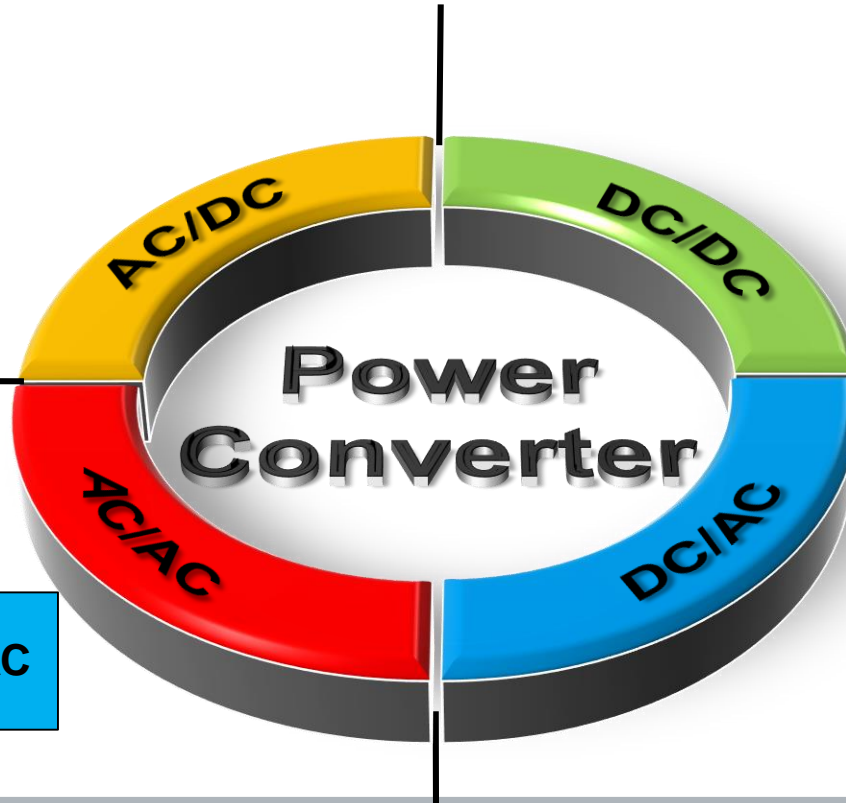
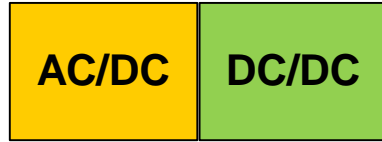

Power Electronics Converter Type

Rectifier

Switching
Regularor

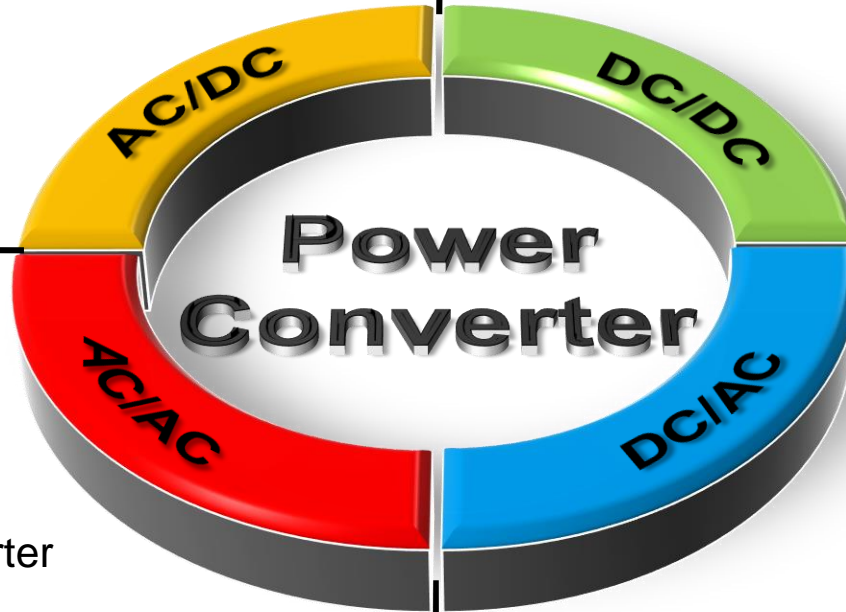

AC controllers
Cycloconverters
Matrix Converter
Typically rectifier + inverter

Inverter



Power Electronics



PSU



LED Driver



BLDC Motor

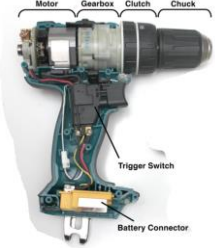

Battery Powered DC Motor

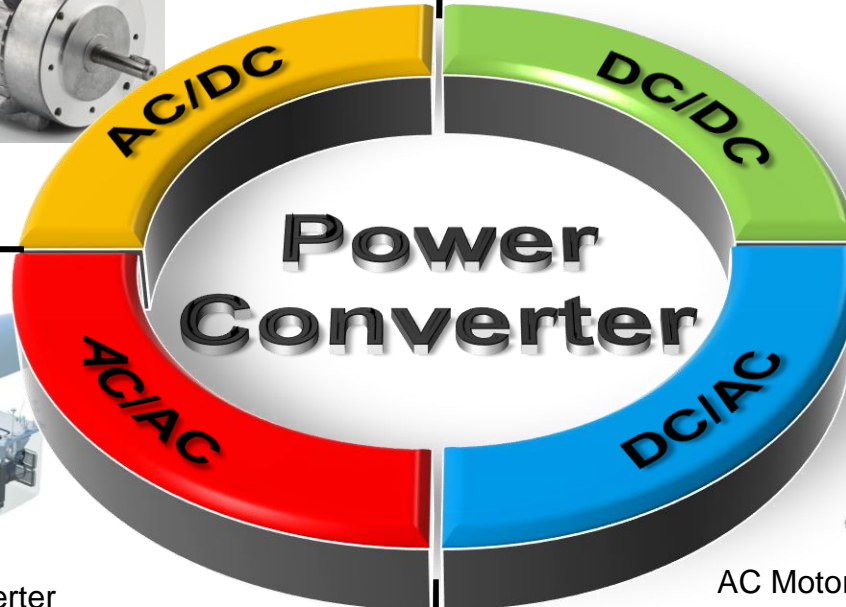

Variable Frequency AC Motor



Wind Energy Converter



AC Motor Battery powered



Solar Converter

Power Electronics

Optimized Efficiency

- Reduce efforts and space for heat sinks
- Reduce weight
- Reduced System Cost
- Lower Power Consumption

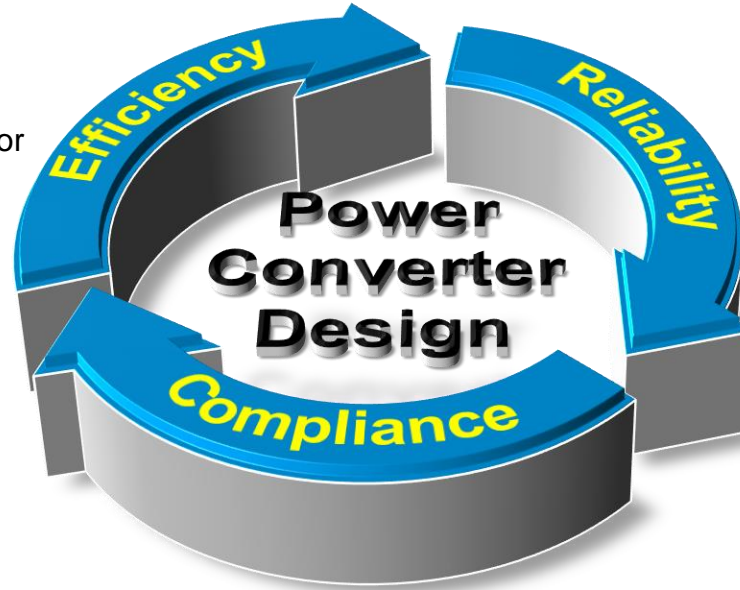

Highest Reliability

- Service-optimized
- Long life products

Required from Automotive, Energy Generation and Industry

EMC Compliance is mandatory

e.g. EN55022, EN55011, IEC-61800-3, IEC-61000-4-x, IEC-61000-3-2

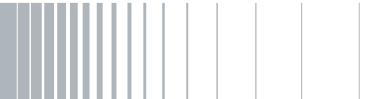

Power Electronics

Circuits used

- Types of power supplies
 - Boost async
 - Synchronous rectifier
 - Buck sync/async
 - Other Sepic/Cuk/Zeta/flyback
 - LLC – Converter
 - Multiphase Converter
 - Half & Full Bridge Converter
 - Three phase full bridge
 - Auxiliary circuits μC , DSPs and FPGAs
 - Gate Driver

Capacitor

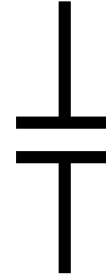

Diode

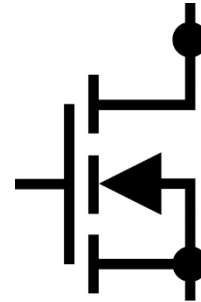

MOSFET
-Silicon
-GaN

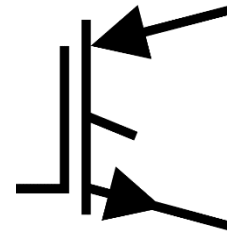

IGBT
-SiC



Coil



Power Electronics

Circuits used

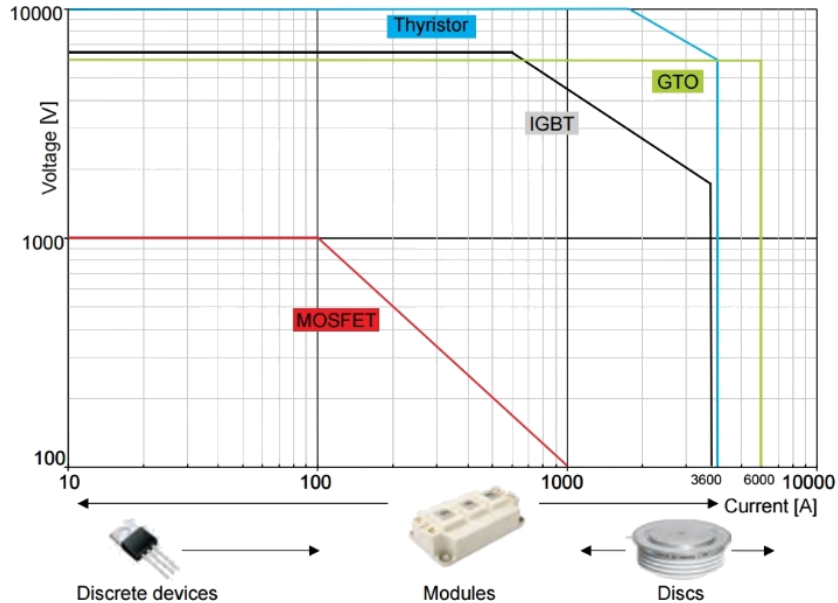

MOSFET are the predominant devices for a large # of applications

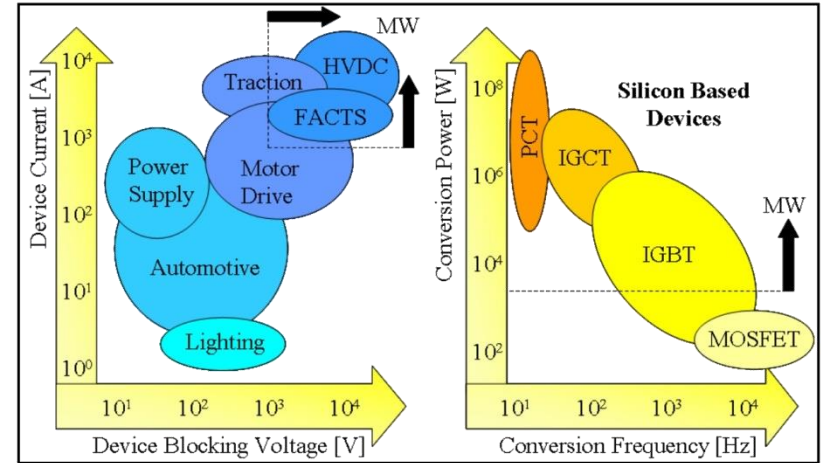

Power Semiconductor devices and applications.

HVDC : High Voltage Direct Current
 FACTS : Flexible AC Transmission Systems
 PCT : Phase Controlled Thyristor
 IGCT : Integrated Gate Commutated Thyristor
 IGBT : Insulated Gate Bipolar Transistor
 MOSFET : Metall Oxid Semiconductor Field Effect Transistor

Power Electronics

Rectifier AC-DC Conversion

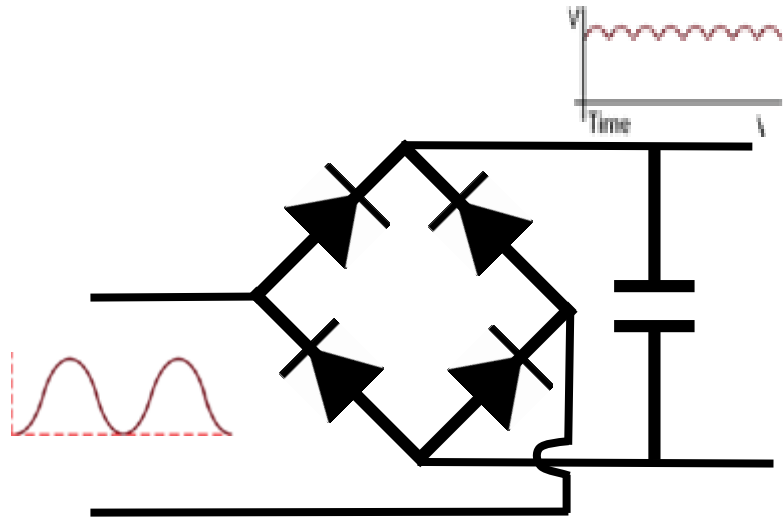

Diode based

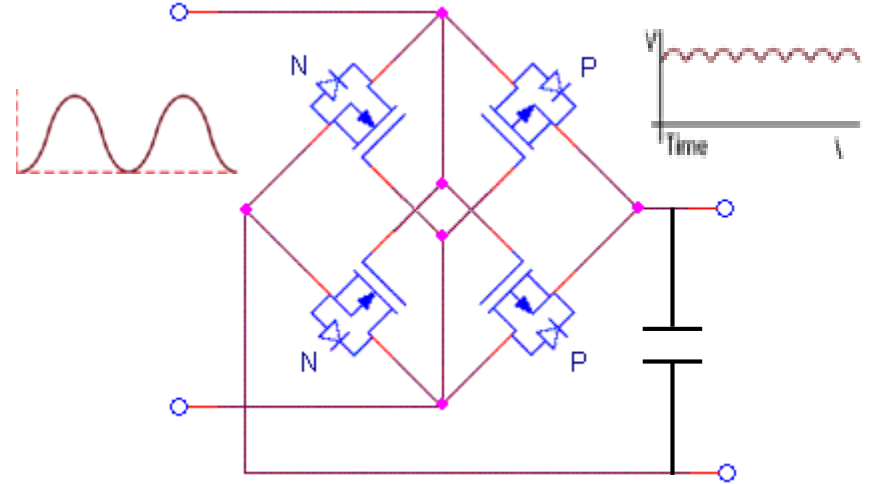

Active Rectification
MOSFET based



Power Electronics

Converter DC-DC Conversion (Hard switching Boost/Buck)

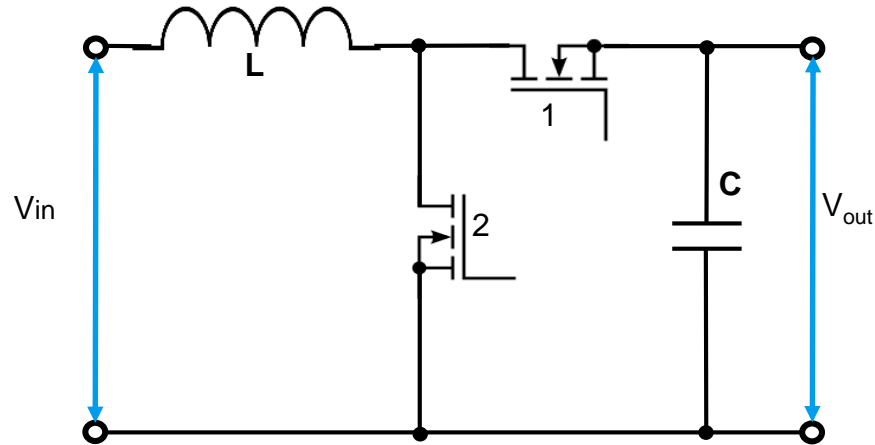

Boost (Up) Converter
 $V_{out} > V_{in}$

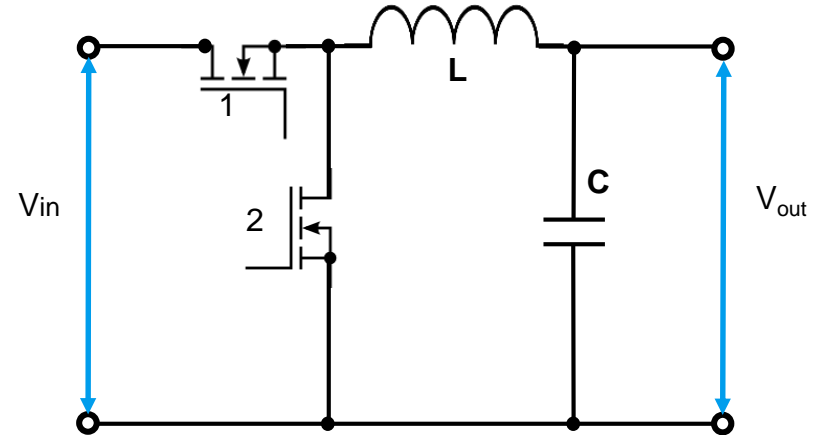

Buck (Down) Converter
 $V_{out} < V_{in}$



Power Electronics

Inverter DC-AC Conversion (Pulse Width Modulation)

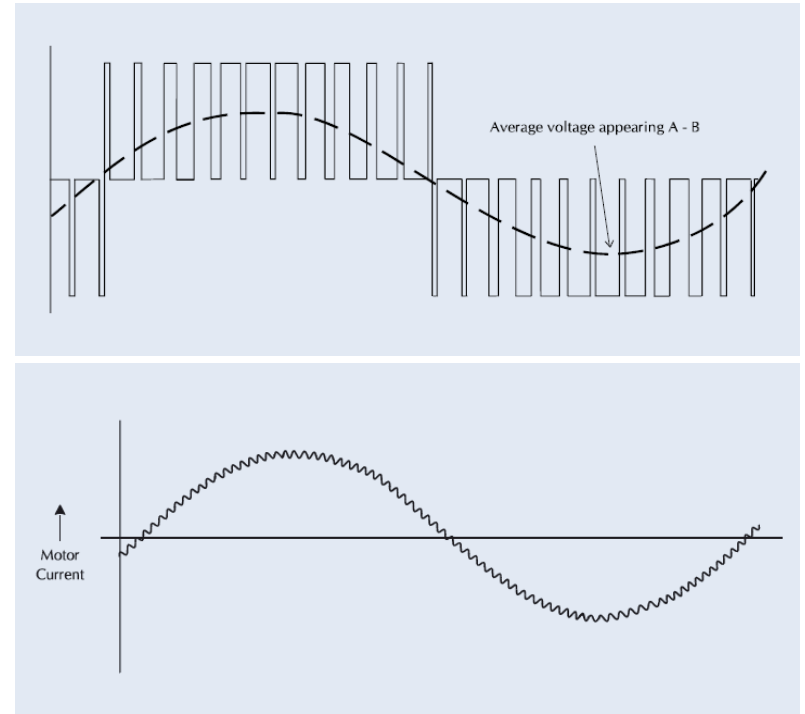
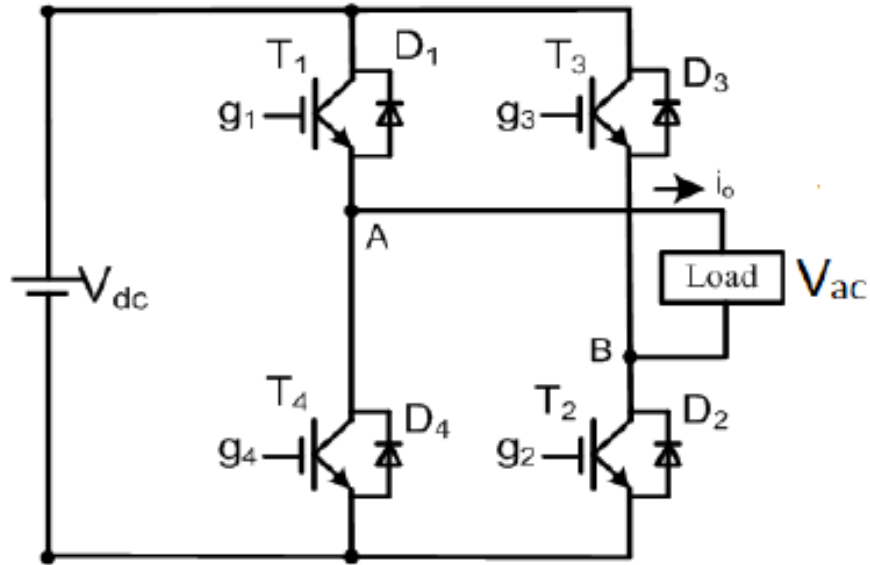

Power Electronics

Inverter Drive control (3 phase inverter)

- For drive control, power inverter, build with
 - MOSFETs (low Power < 30 KW)
 - IGBT (mid Power < 500 KW)
 - Thyristors (high Power > 500 KW)
- Typically low switching frequency (500 Hz .. 16 kHz), mechanical inertia dictates the responsiveness
- Commercial drive control modules can typically control DC, sync AC, async AC and step motors (Nidec, HEW, Rockwell, Bosch,...)
- Power inverter can feed DC power into the power network (see Power HW in-the-loop)

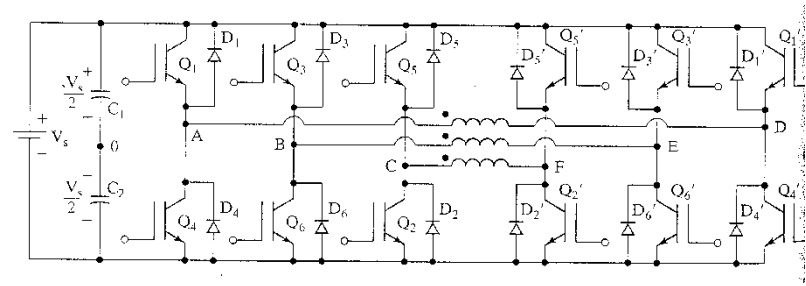

Power Electronics

Inverter Drive control (3 phase inverter)

- A 3 phase inverter would consist out of 3 single phase full bridges
 - all 120° phase shifted
 - This requires 12 transistors, 12 Diodes, and 3 transformer ☹
- Real world inverter consist out of 6 transistors, 6 Diodes
 - Still a concept of three totem pole circuits (legs)
 - PWM is used to control the gates and create indirectly a sinusoidal current
 - Motor load is the inductance, inverters may need an inductance

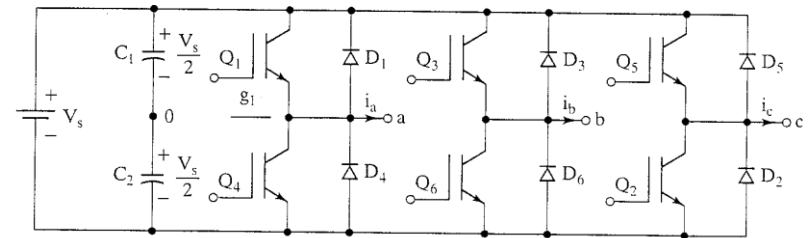

Power Electronics

Power MOSFET switching (turn on behavior)

■ Turn on in steps

- **T0 - T1:** C_{gs} is charged from zero to $V_{GS(th)}$. There is no change in V_{DS} or I_D .
- **T1 - T2:** $V_{GS(th)}$ to the plateau voltage V_{gp} . I_D rises from 0 A to the full load current, no change in V_{DS} . associated charge $Q_{GS} = \int_0^{V_{gp}} C_{GS} \cdot dV$
- **T2 - T3:** Miller plateau. C_{DG} is charged to supply voltage V_{IN} and holds it till I_D has peaked to I_{LOAD} at T2. Between T2 and T3, the negative charge of $(V_{IN} - V_{gp})$ is converted to the positive charge corresponding to the plateau voltage V_{gp} . This is also seen as the fall of the drain voltage from V_{IN} to near zero. The charge associated is approximately the integral of C_{DG} from zero to V_{IN} and specified in the datasheets as Q_{DG} .
- **T3 - T4:** gate voltage rises from V_{gp} to V_{GS} , V_{DS} and $I_D \sim \text{const}$. $R_{DS(on)}$ reduces marginally with rising gate voltage.

■ Dynamic Switching loss is power dissipation from $t_1 - t_3$

$$\text{and } P = \int_{T_1}^{T_3} V_{DS}(t) \cdot I_D(t) \cdot dt$$

- higher rise/fall times lower losses

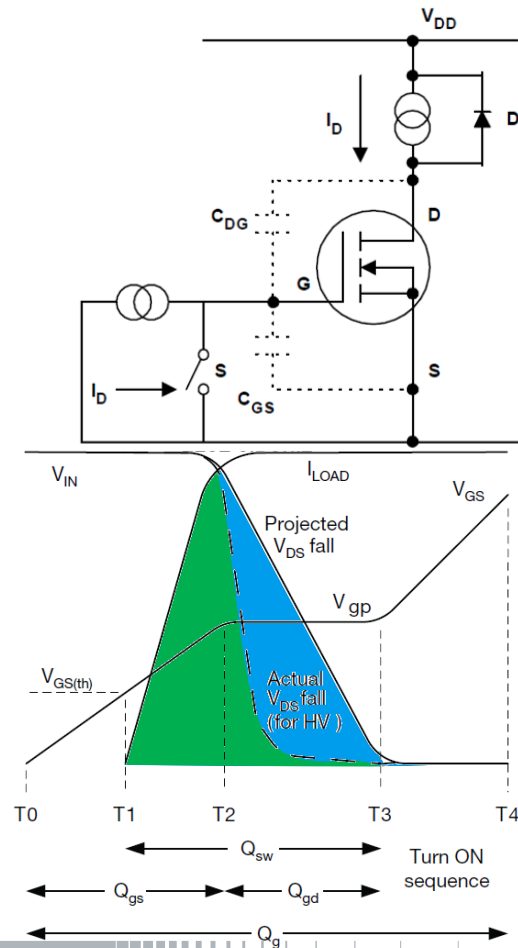

Power Electronics

Power MOSFET switching (turn on behavior)

- The rise time measurement depends also on the system bandwidth.
- Ensure that the intrinsic rise time is X5 time lower than the rise time to measure
- Examples
 - RTH1002 60 MHz < 5.8 ns
 - RTH1004 500 MHz < 700 ps
 - RTA4000 1 GHz < 350 ps
 - RTO2000 6 GHz < 76 ps

$$t_{\text{rise_measure}}^2 = t_{\text{rise_intrinsic}}^2 + t_{\text{rise_signal}}^2$$



Power Electronics

Typical measurements

- Power Consumption / Efficiency / Standby Power
- Power Quality / Power Factor
- Voltage and Current Waveform Analysis
- Ripple
- Inrush Current / Transients
- Startup / shutdown behavior
- Load regulation
- PWM
- EMC / Harmonics
- ...

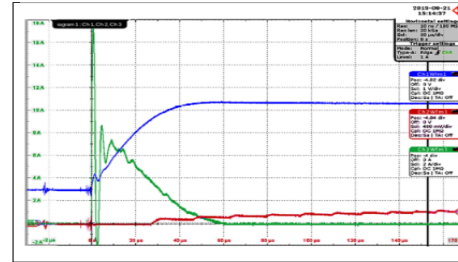
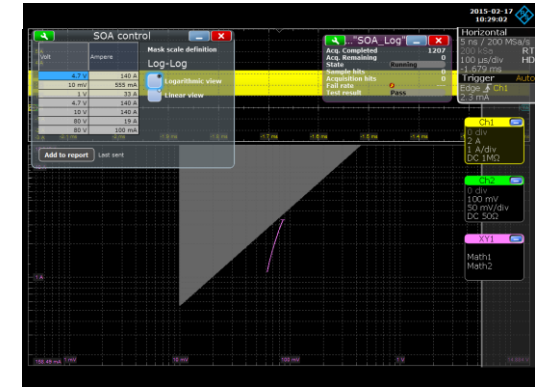
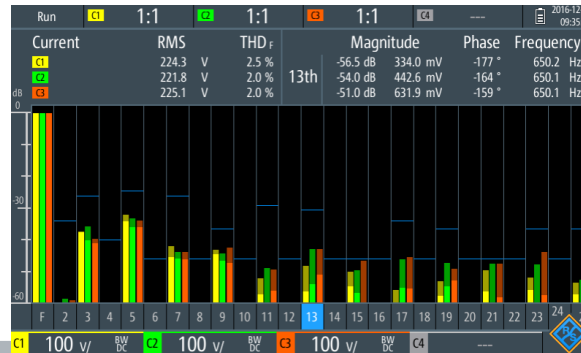
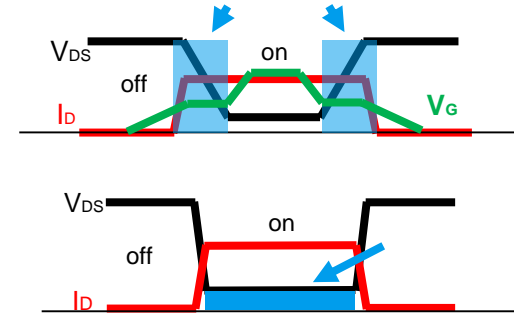

Figure 5: Waveform display of manual Inrush Current and start-up/soft-start measurements (Ch 1 blue - Vin / Ch 2 red - Vout / Ch 3 green - Iin)



Power Electronics

Measurements challenges

- Measure small voltages at large common mode voltages
- Measure different voltage levels at different potentials at the same time
- Measure fast Rise-/ Fall-times – particular @ WBG Materials like GaN, SiC
- Safety: Wrong connection of ground lead can cause short circuit and very large currents

- → **Floating Measurements on multiple channels are needed**

- → **New WBG Components additionally require High Bandwidth measurements**



Power Electronics

Floating Measurements Techniques: Float The scope



- I The floating voltage, V_{FLOAT} , may be hundreds of volts and is on the chassis!
- I All grounds are at the same level
- I Signal distortion may result from the parasitic inductance and large bridging capacitance to earth ground.

Power Electronics

Floating Measurements Techniques: A-B Method



- I Can be ok for low frequency measurements with LOW common mode signals.
- I Measuring small differential signals with HIGH common mode signals will likely overdrive the scope inputs.
- I Probes should be the same model and be adjusted to closely match each other.

Power Electronics

Floating Measurements Techniques: Isolated scope

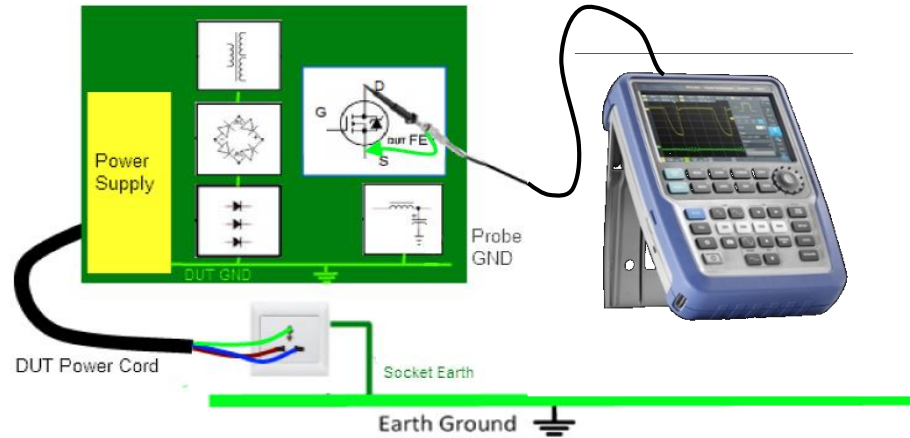

R&S®Scope Rider

- ▮ 60 MHz to 500 MHz
- ▮ 5 GS Sampling rate
- ▮ 50 000 waveforms / second
- ▮ 10-bit A/C converter
- ▮ 2 mV/div to 100 V/div
- ▮ Up to 200 V offset range
- ▮ 33 automatic measurements

- ▮ Isolated input has no direct electrical connection to earth ground.
 - ▮ **Great DC & low frequency CMRR!**
- ▮ Isolated probes are not true differential probe because the input impedance between the tip and reference lead are not balanced.

Power Electronics

Floating Measurements Techniques: High Voltage Differential Probes

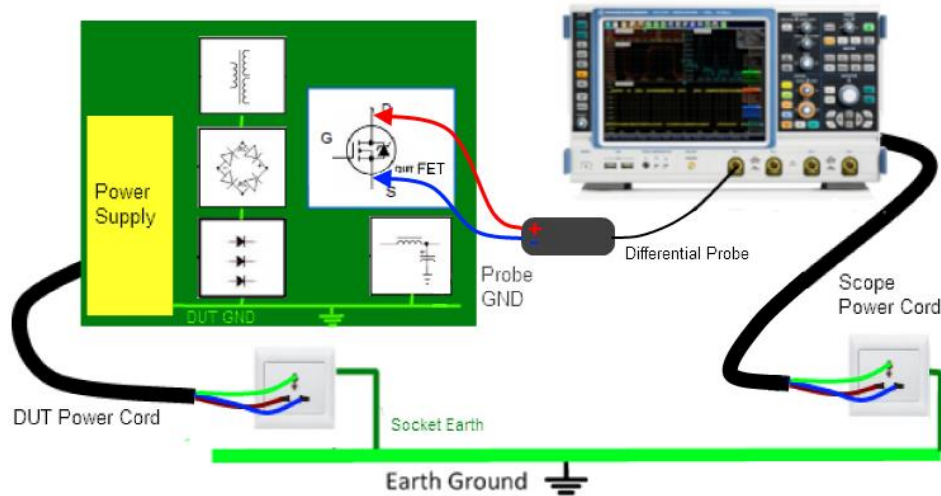

- I Can accurately measure small differential voltages in the presence of large common-mode voltages up into the thousands of volts.
- I High input impedance on both inputs minimize loading and measurement errors.

Power Electronics

Floating Measurement Techniques: Pro's and Con's

	Floating the Scope	"A minus B"	High-Voltage Differential Probes	Isolated Channel Scope
Safety	Dangerous!	Ok	Very good	Very good
Flexibility	Limited all channels have ground connected	Limited, needs two channels per signal	Very good	Very good (limited by max ground potential rating)
Sensitivity	Very good	Very good	Good (typ. 50:1 or 100:1)	Very good (10:1 attenuation)
Accuracy	Very good	Not good	Very good	Very good
Bandwidth	Very good	Not good	Good (typ. <=200 MHz)	Very good (up to 500 MHz)
CMRR	Not good	Very bad	Very good	Good
Conclusion	Not recommended!	Not recommended!	Recommended if <u>high CMRR</u> is critical at high frequencies (i.e. fast switching) or high-dynamic range measurement necessary	Recommended if high bandwidth required but CMRR at high frequencies not critical and limited budget

Power Electronics

Measured Common Mode Rejection Ratio

- Galvanically isolated input channels behave as “differential” with some limitations
 - Truly differential for DC signals
 - Differential with frequency dependent CMRR (common mode rejection ratio) for AC signals
- Isolated channel scope vs high-end active differential probe
 - Better (or similar) CMRR for low frequencies
 - Lower CMRR for high frequencies

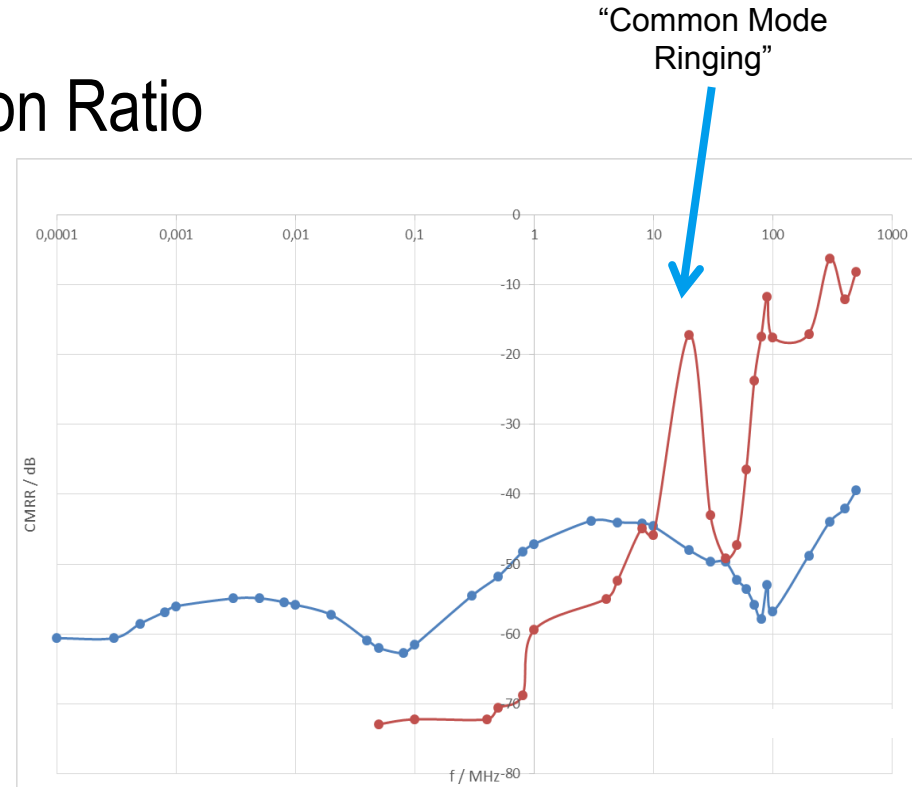

Measurement Results CMRR
Isolated Scope (red) vs Standard Differential Probe (blue)

Power Electronics

Good probing for good results

Keep short connections to the DUT

Wrong

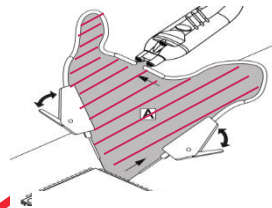
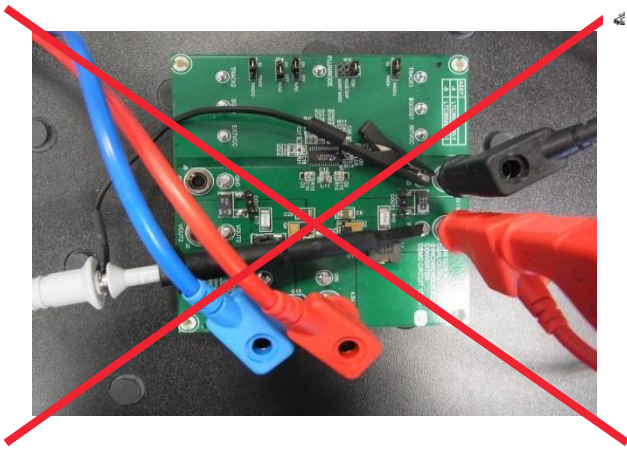

$$f_{\text{Resonant}} = \frac{1}{2\pi\sqrt{L \cdot C}}$$

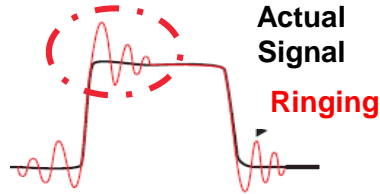

Right

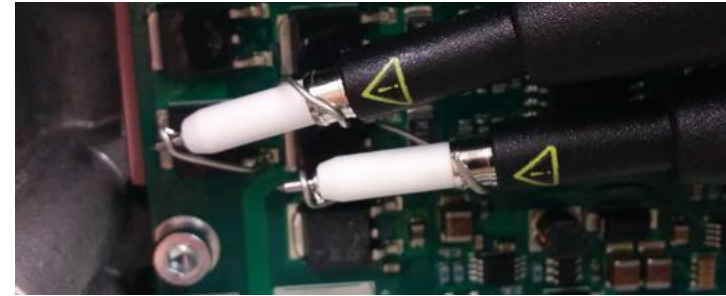

Power Electronics

Probing power Circuits

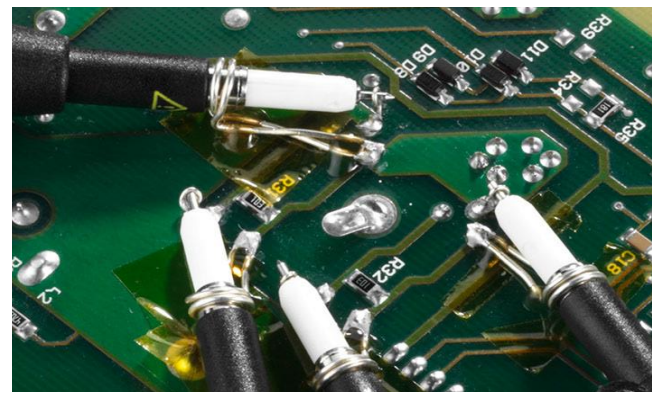

- Probing with low inductance is important
- Long wires and GND clips are bad
- Using spring tips without preparation in HV is dangerous
- Proposed solutions
 - Wire wraps
 - Probe adapters (PMK) – limited voltage
 - PCB holes for 2.5mm spring tip

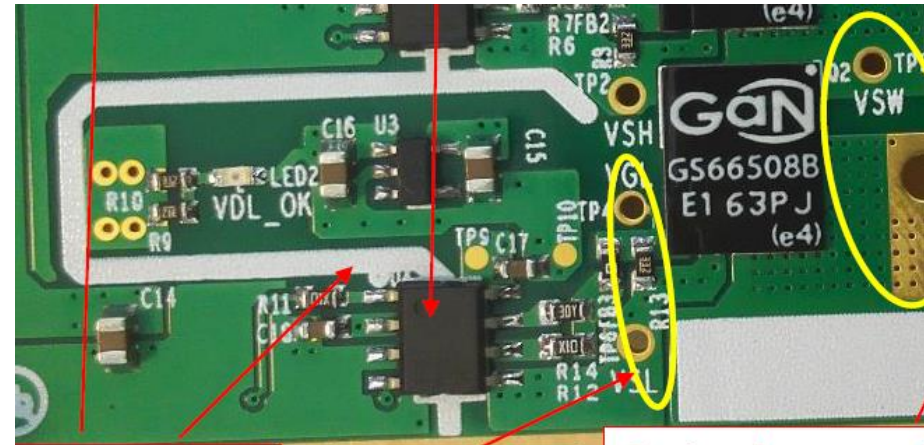

Isolation Barrier

VGS probe

Optional current sense
Use copper foil to

Power Electronics

Real Measurement Connection to DUT

A) HV Diff Probe – R&S® RT-ZD01



B) Isolated Channel Scope
R&S®Scope Rider



long leads



short leads

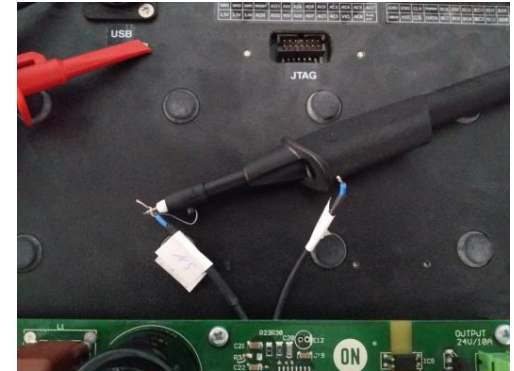

Power Electronics

Common Mode Suppression – 400 Vpp Half-Bridge Output

- Half-Bridge Output with 400 Vpp
- Comparison
 - A) Standard High-Voltage Diff Probe
 - B) Isolated Channel Oscilloscope

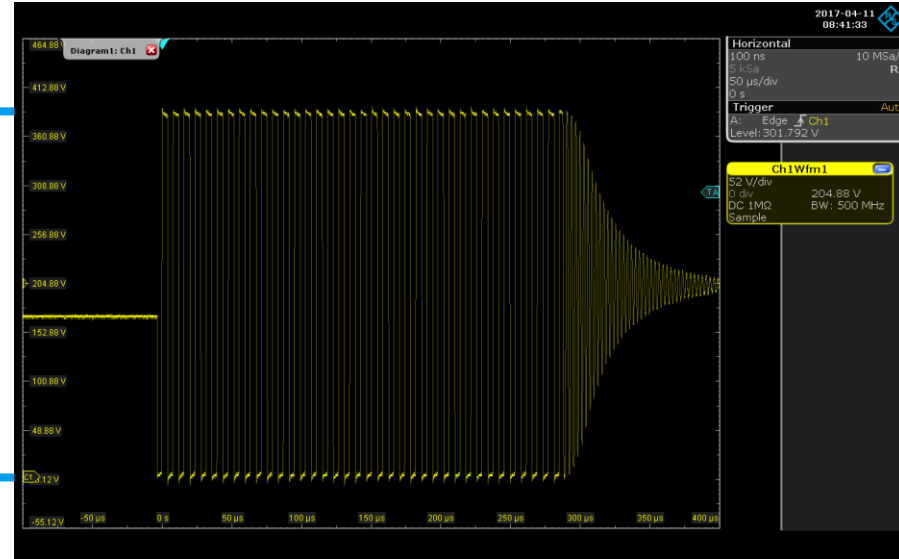
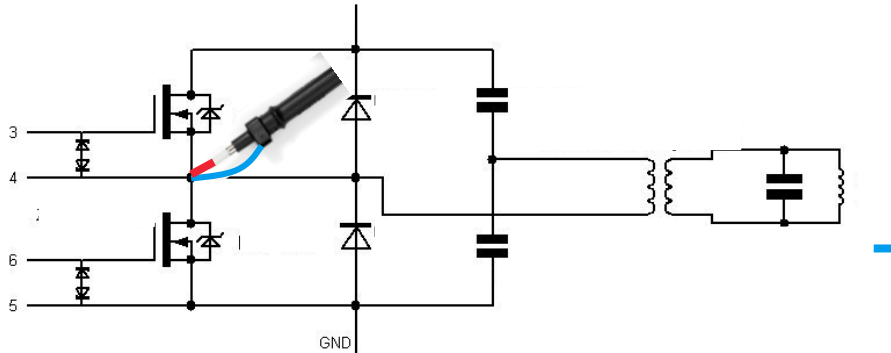

Power Electronics

400 Vpp Common Mode Signal with HV Diff probe (100:1)

- Almost no Ringing
- 410 mVpp remaining signal
 - → ~60dB CMRR
- But
 - ... noisy because of attenuation
 - limited bandwidth (100 MHz in this case)

410 mVpp

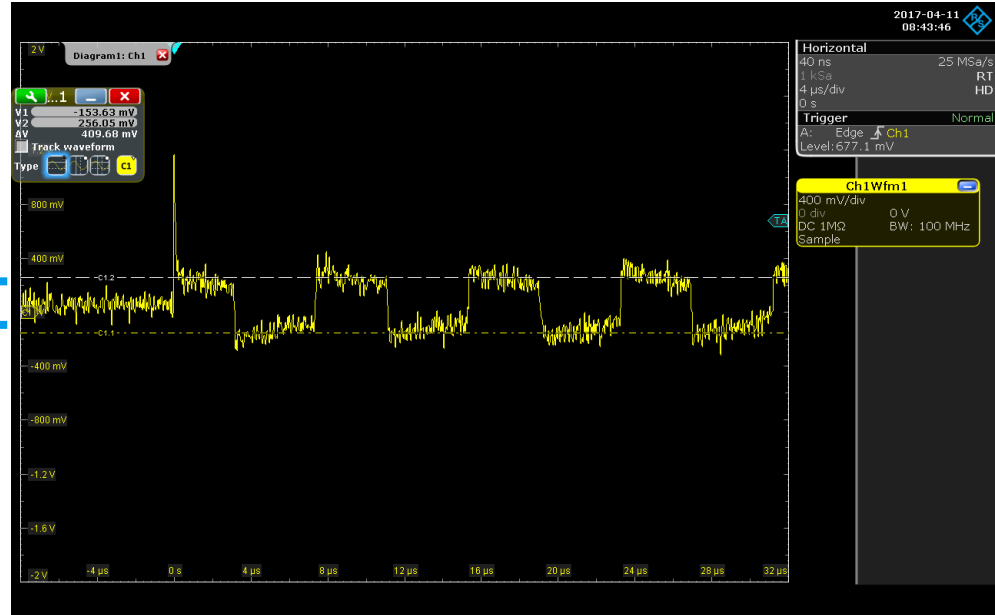

Power Electronics

400 Vpp Common Mode Signal with Isolated Channel Scope

- Some ringing
- Only 230 mVpp remaining signal
 - → ~65dB CMRR
- Lower noise
- 500 MHz bandwidth

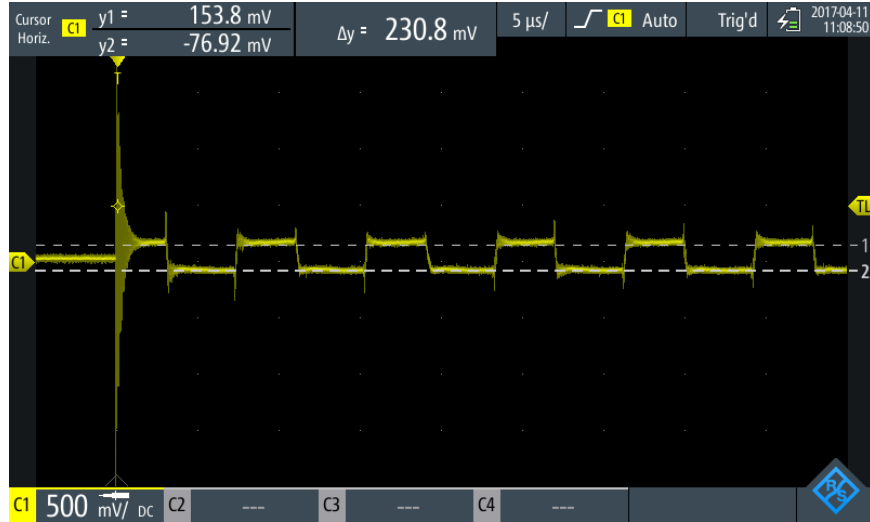

Power Electronics

Real Measurement Connection to DUT

(long leads)



(short leads)

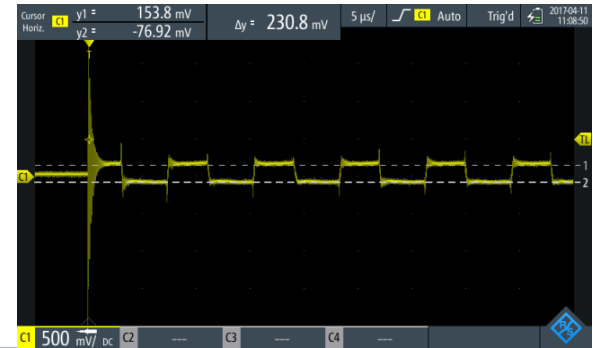
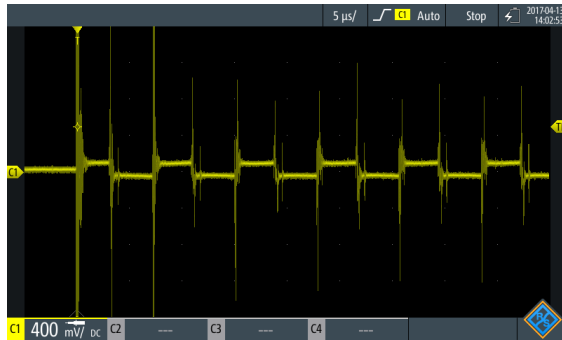

Power Electronics

Electrical Measurement Safety Measurement Categories

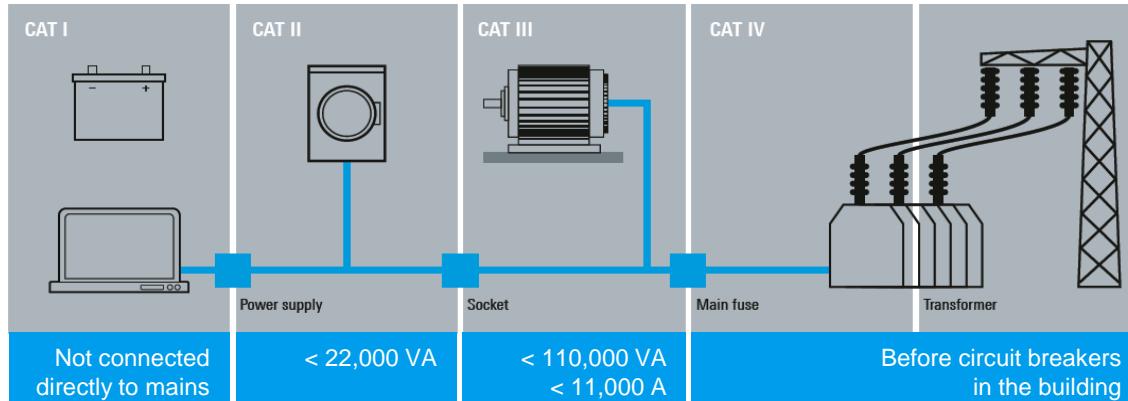

- Defined by IEC 61010-1 and UL 61010B-1
- Generally higher the CAT rating of an instrument, safer it is to operate in the environment.
- Ensure working within transient limit

Example: Instrument rating of CAT III 300V and CAT II 600V

Means that:

- It can withstand a transient voltage of 4000V.
- Should not be used for CAT III circuits of more than 300V operating voltage.
- Definitely not to use in CAT IV circuits.

Rated Voltage	UL 61010B – 1 (Transient)			IEC 61010-1 (Transient)		
	I	II	III	II	III	IV
150V	800V	1500V	2500V	1500V	2500V	4000V
300V	1500V	2500V	4000V	2500V	4000V	6000V
600V	2500V	4000V	6000V	4000V	6000V	8000V
1000V	4000V	6000V	8000V	6000V	8000V	12000V
Resistance	30 ohm	12 ohm	2 ohm	12 ohm	2 ohm	2 ohm

Power Electronics

Using the R&S® Scope Rider Input Connections



When using cables direct such as BNC connectors

CAT IV 300 V

When using with R&S 10:1 probes

**CAT III 1000V;
CAT IV 600V**



Power Electronics

Electrical Measurement Safety

- Separate Isolation:
 - Safe to use up to 600 V CAT IV / 1000 V CAT III
 - All oscilloscope channels
 - Digital multimeter (part of 2 channel RTH version)
 - MSO channel and communication interfaces

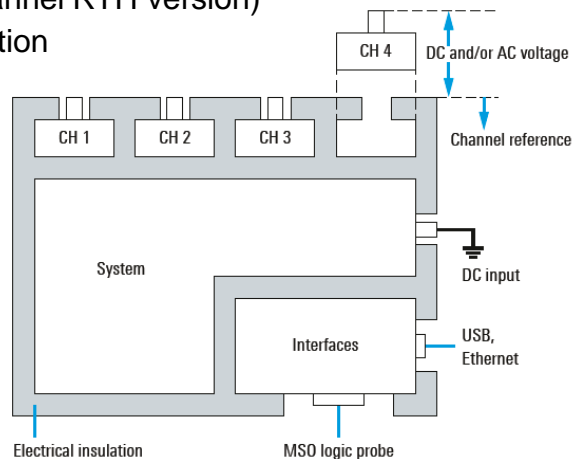

R&S® Scope Rider - RTH

Power Electronics

Electrical Measurement Safety: Arc Flash

- What is Arc Flash?
- How does Arc Flash happen?

“An arc flash is a sudden release of electrical energy through the air when a high-voltage gap exists and there is a breakdown between conductors,” according to the Electrical Safety Foundation International



An arc flash can be spontaneous, or it can result from inadvertently bridging electrical contacts with a conducting object, according to the Electrical Safety Foundation International. Other causes can include dropped tools, the buildup of conductive dust or corrosion

Power Electronics

Electrical Measurement Safety: Solution for dangerous Environments

- Wireless LAN remote control for dangerous measurement situations (high-voltage)



Wireless LAN
remote control

Web browser interface:

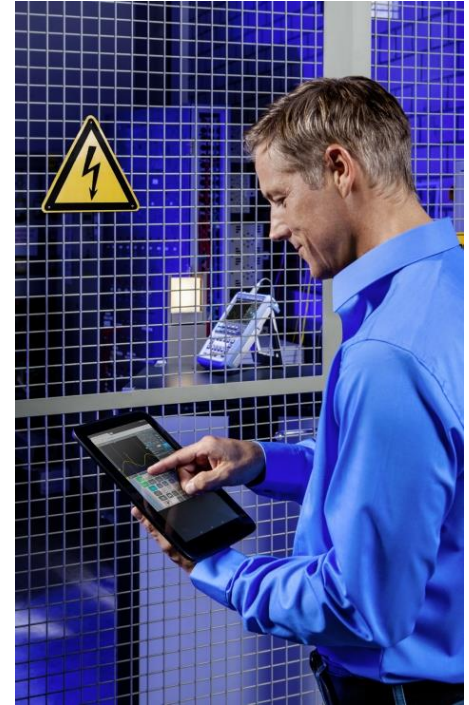
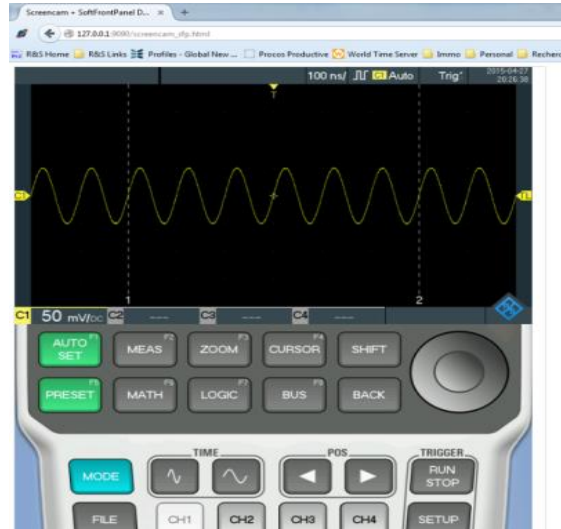

Power Electronics Demonstration

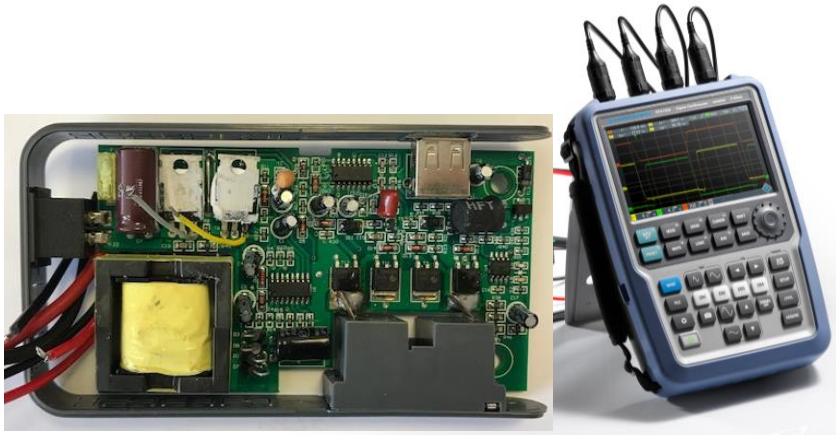

- Measure de V_{g1a} , V_{d1a} , V_{g4c} , V_{ac}
- 2 differents références
- Interest for timing, rise time, voltages...
- Maybe versus temperature...

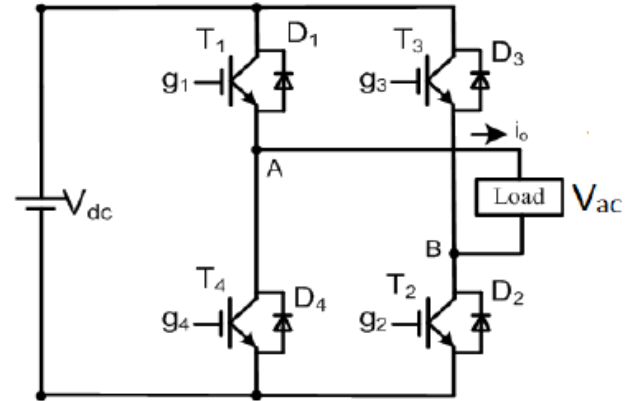

Power Electronics

Maximum Input Voltage

- Maximum (single-ended or differential) input voltage
- Maximum (isolation or input to operator potential) voltage

R&S®Scope Rider itself has:

300 V CAT IV maximum input voltage **without probe**

600 V CAT IV, 1000 V CAT III maximum input voltage **with probe**

600 V CAT IV or 1000 V CAT III isolation voltage (voltage to earth / operator potential)

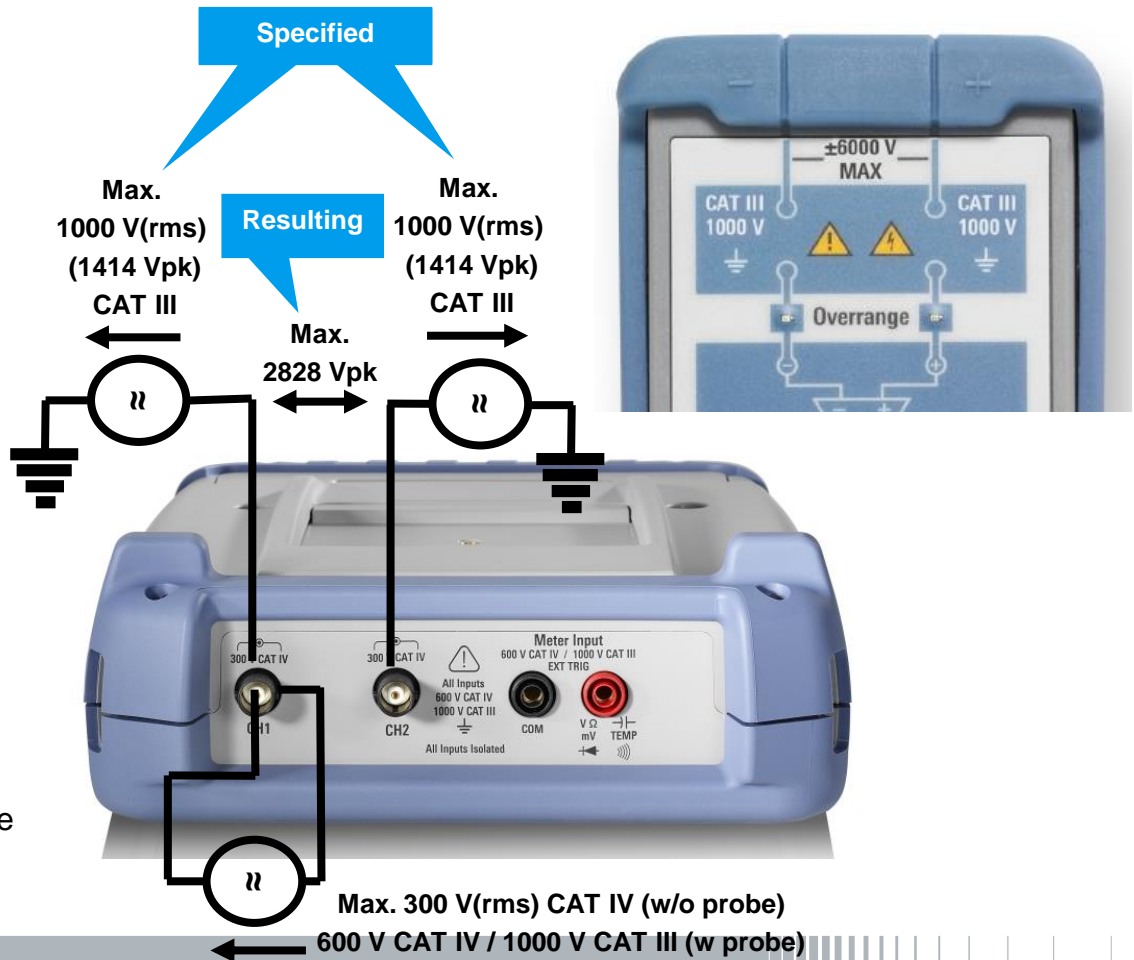

Power Electronics

Maximum Input Voltage - Derating

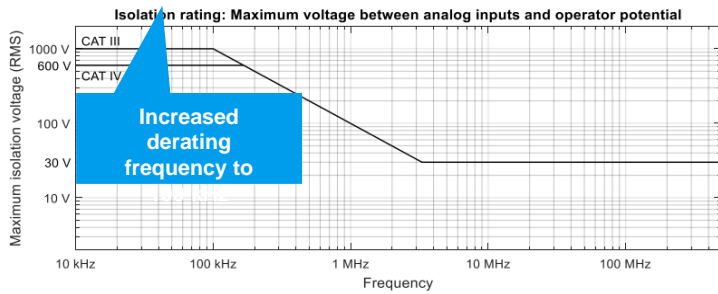
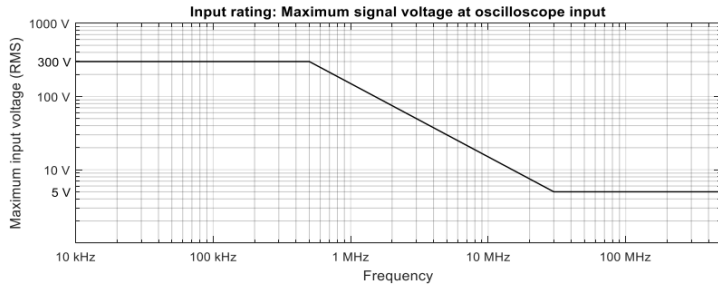

RT-ZHD derating will start at a significantly higher frequency ~1-4 MHz

Power Electronics Measurements and R&S Solutions



RTM3000 / RTA4000



RT-ZHDxx

High Voltage differential Probe
Up to 6kV
Up to 200MHz BW
+/- 2000V Offset compensation



RTE / RTO



RTH

Power Electronics

Measurements and R&S Solutions

■ Example

Half bridge Switching Analysis
Measuring High- and Low
Side Switch V_{GS} and V_{DS}

■ Challenges

- $V_{GS,high\ side} = 16V$ @ common mode voltage of 400V
- Channel 1 (4V/div) is connect to ground
- Channel 2 (4V/div) is floating
- Channel 3 (200V/div) is floating
- Steep Edges \rightarrow High T&M BW

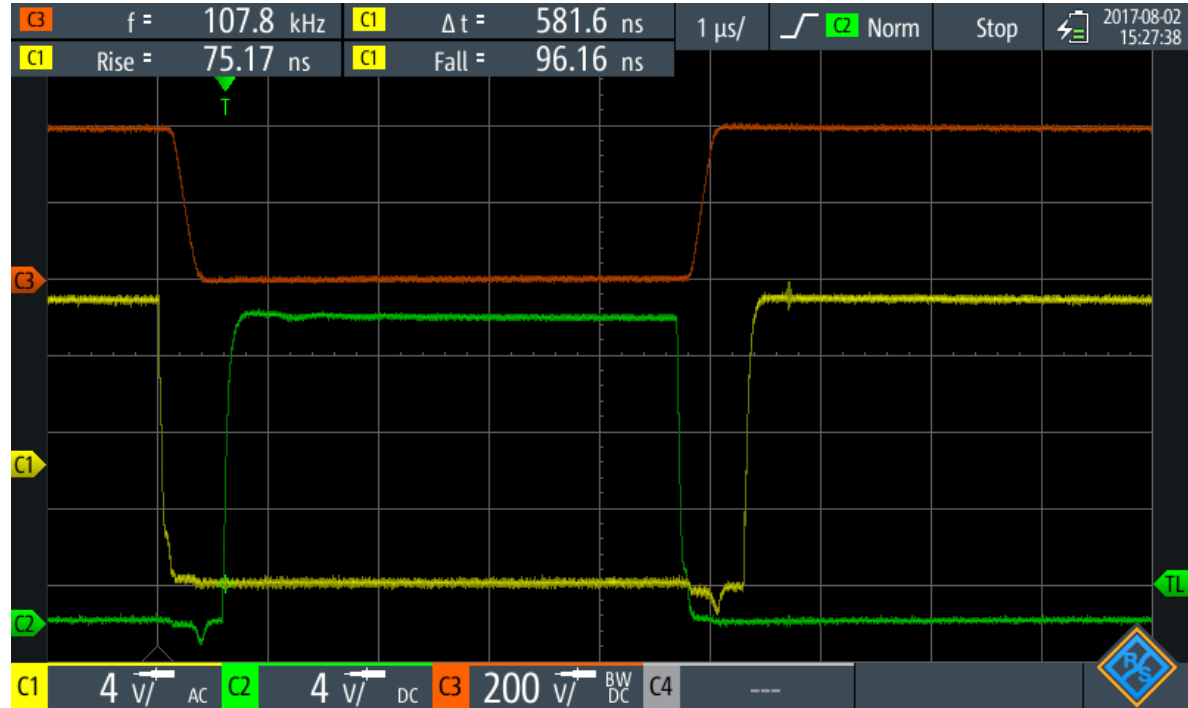

Power Electronics

Harmonic Analysis R&S®RTH-K34

Automatic RMS and THD_F / THD_R measurement for each channel

Magnitude (dB or %), phase and frequency measurement for the selected harmonic

Up to 4 channels in parallel
(3 shown here)

Max / current harmonic level display:
lighter / darker bar

Base frequency (F):
50 Hz, 60 Hz, 400 Hz or user defined (up to 1 kHz)

Automatic limit test:
EN50160 or user defined,
limit lines for each harmonic displayed

Up to 64 harmonics
(25 shown here)

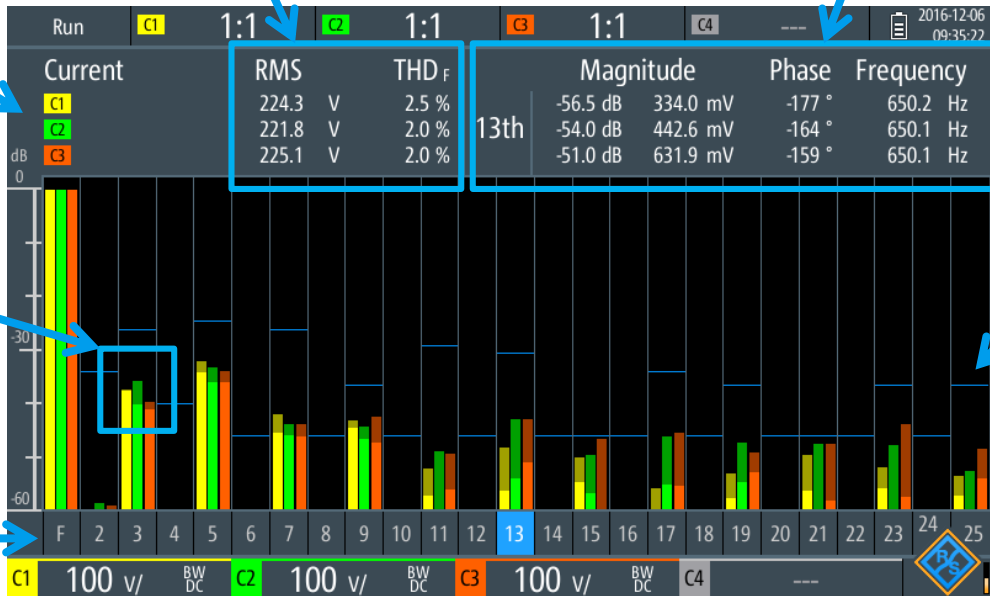

Power Electronics

Power analysis R&S®RTx-K31

- Automatic power measurements
- Assistant de câblage (wizard)
 - Autoset
 - Fast results
- Complete report measurements
- Deskew kit fixture RT-ZF2
 - Compensate delay between current and voltage probes

- Conforme aux standards
 - EN61000-3-2 classe A,B,C,D
 - MIL-STD-1399
 - RTCA DO-160

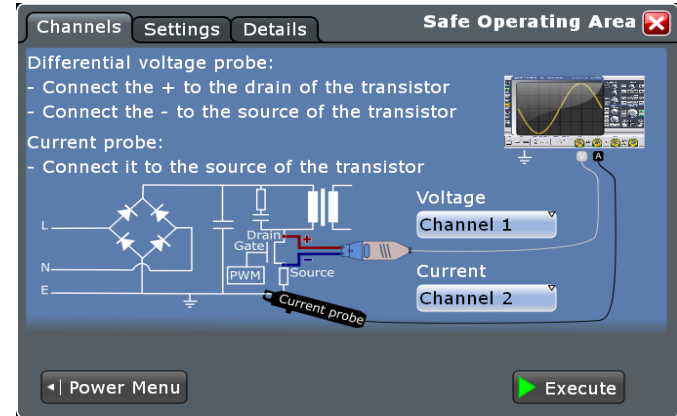

Power Electronics

Power analysis R&S®RTx-K31

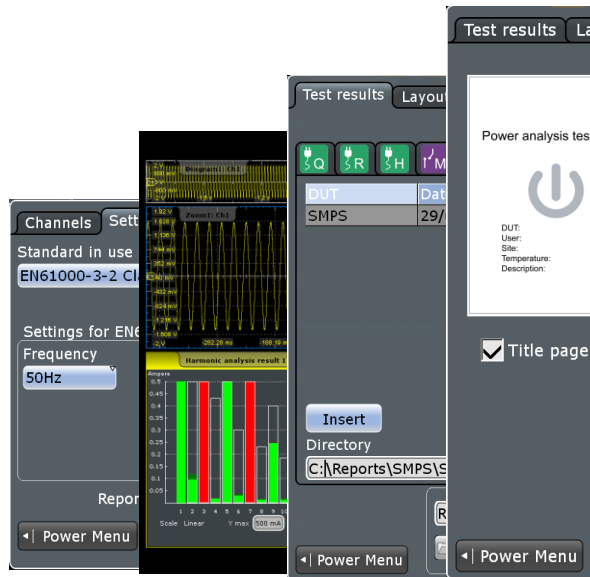

Date: 30/08/2013
Time: 13:32:21
Equipment: RTO1004
Serial number: 100009

Harmonics

Measurement Setup:

Settings:
Standard: EN61000-3-2 Class A
Frequency: 50Hz
Autoscale signal: Yes

Vertical setup:

Probes:	Source	Name	Unit	Gain/Att.
	Voltage Channel 1	None	Volt	1 V/V
	Current Channel 2	None	Ampere	50 A/V

Channels:

Source	Scale	Offset	Coupling	Deskw	Bandwidth
Voltage Channel 1	400mV/div	0V	1MOhm DC	0s	Full
Current Channel 2	400mA/div	0A	1MOhm DC	0s	Full

Trigger setup:

Type	Source	Level	Slope
Edge	Channel 1	-10mV	Positive

Horizontal setup:

Time scale	Acq. time	Sample rate	Resolution	ADC sample rate
400ms/div	4000ns	10000MHz	4s	250kSa/s

Harmonic order n	Frequency	Harmonic current	Peak harmonic current	Maximum permissible harmonic current	
12	602Hz	695µA	695µA	153.33mA	Pass
13	652.2Hz	135.71mA	135.71mA	210mA	Pass
14	702.4Hz	722µA	722µA	131.420mA	Pass
15	752.5Hz	112.45mA	112.45mA	80mA	Fail
16	802.7Hz	696µA	696µA	115mA	Pass
17	852.9Hz	102.79mA	102.79mA	70.58mA	Fail
18	903Hz	706µA	706µA	102.22mA	Pass
19	953.2Hz	85.58mA	85.59mA	63.15mA	Fail
20	1003.4Hz	694µA	694µA	62mA	Pass

Power Electronics

Measurements and R&S Solutions

The new WBG components push PWM frequencies up and decrease rise/fall times

Possible GaN rise/fall time <5nsec



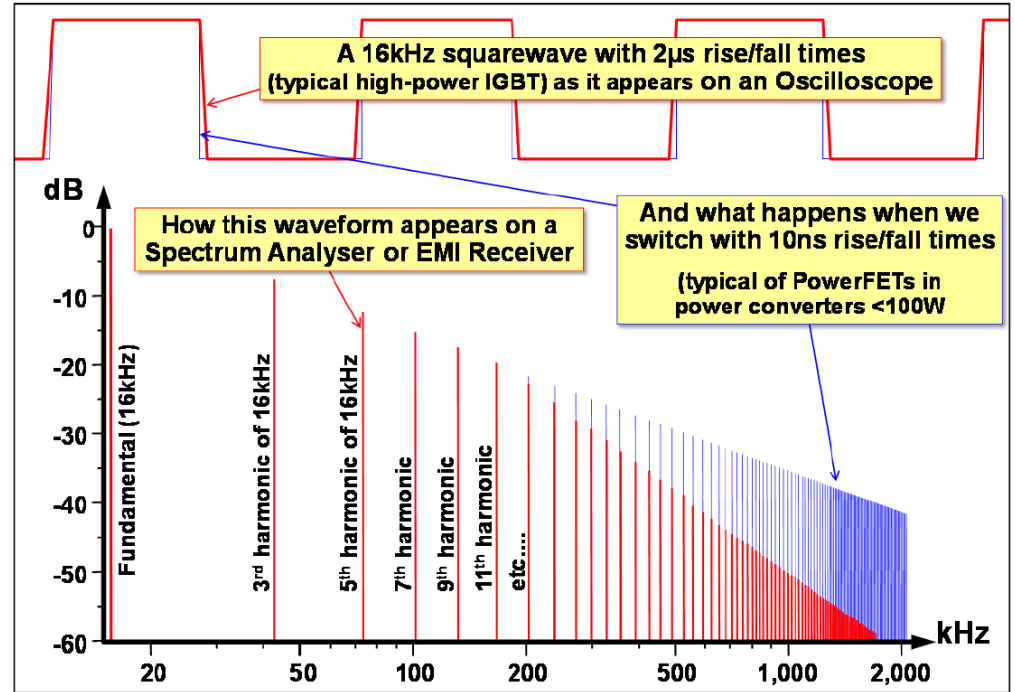

Today's Switching Frequency up to 100kHz @ Power Converters!

Lower Power → Higher Switching Frequency!



Power Electronics



R&S High-Voltage Probe Portfolio High-Voltage Probe Portfolio

	RT-ZD01 RT-ZD002/003	RT-ZHD07/15/16/60	RT-ZH10/11	RT-ZI10/10C/11 with RTH
	 <p>New</p>	 <p>New</p>		
Advantages	<ul style="list-style-type: none"> • Price, • BNC Interface 	<ul style="list-style-type: none"> • Bandwidth • High CMRR • Low input capacity 	<ul style="list-style-type: none"> • Price • Bandwidth 	<ul style="list-style-type: none"> • Price • Bandwidth • Medium to high CMRR • Mobility needed
Disadvantages	<ul style="list-style-type: none"> • 25 MHz 		<ul style="list-style-type: none"> • No floating measurement 	<ul style="list-style-type: none"> • Manual work for good connection needed • Coupling capacity between RTH input channels
When to use	<ul style="list-style-type: none"> • Budget limited • Bandwidth not critical • BNC interface required 	<ul style="list-style-type: none"> • Bandwidth important • CMRR critical • Coupling capacity critical • Input capacity critical 	<ul style="list-style-type: none"> • Bandwidth critical • Single-ended measurement sufficient 	<ul style="list-style-type: none"> • Bandwidth critical • CMRR important • Mobility / Battery operation needed • Budget limited



Power Electronics

R&S Current Probes Portfolio Portfolio and Recommended OEM

Current Probes with BNC Interface		Current Probes with R&S Interface	
RT-ZC02 RT-ZC03		20 kHz, 1000 Arms, 2000 Apk 100 kHz, 20 Arms, 30 Apk	RT-ZC05B RT-ZC10B RT-ZC15B RT-ZC20B
RT-ZC10 RT-ZC20 RT-ZC30		10 MHz, 150 Arms, 300 Apk 100 MHz, 30 Arms, 50 Apk 120 MHz, 5 Arms, 7.5 Apk	
			2 MHz, 500 Arms, 700 Apk 10 MHz, 150 Arms, 300 Apk 100 MHz, 30 Arms, 50 Apk

Recommended Rogowski Probes (OEM): PEM UK

CWT Mini & MiniHF

Wide-bandwidth AC current probes

- Bandwidth in the range < 1Hz to 30MHz.
- Two Miniature Coil Sizes (3.5mm or 4.5mm)
- Insulation Voltage 2kV or 5kV peak
- Current Ratings 30A to 120kA



CWT Ultra Mini

Wide-bandwidth AC current probes

- Bandwidth up to 30MHz.
- Coil Size (Max. 1.7mm Cross Section)
- Insulation Voltage 1.2kV peak
- Current Ratings 30A to 6kA



Power Electronics

RT-ZD002 / 003 Low-Cost High-Voltage Differential Probes

- 25 MHz Bandwidth
- 750 V_{peak} and 1400 V_{peak} input voltage
- BNC Interface
- Low noise
- Low price
- Perfectly fits to RTB2000 or low-budget applications



Power Electronics

RT-ZHD07/15/16/60 – High-Voltage Differential Probes

- Up to 200 MHz Bandwidth
 - Achieved with (short) standard cables
- 750 V to 6000 V Input Voltage
- Up to 2000 V Offset Compensation
- Excellent DC Accuracy: 0.5%
 - R&S®ProbeMeter: DC Voltmeter with 0.1%
- Very low noise
- High CMRR
 - 80 dB @ DC – 60 Hz
 - 60 dB @ 1 MHz
 - 30 dB @ 100 MHz
- Overrange Indicator at input
- R&S Probe Interface

Unique

Unique

Detects input voltage and common mode voltage overrange

Unique



Perfect for high-end power electronics measurements

Power Electronics

RT-ZH03/10/11 Passive Probes

- Up to 400 MHz bandwidth
- Up to 1 kVrms input voltage
 - Up to 6000 V puls peak
- 100:1 / 1000:1 attenuation ratio
- Low loading
 - Up to 100 M Ω / 6.5 pF
- Rich set of accessories for RT-ZH10/11
- Low-cost for RT-ZH03



RT-ZH10/11, 400 MHz, 1 kVrms, 6000 Vpk, 100:1 / 1000:1



Good for high-bandwidth, non-floating measurements



RT-ZH03, 250 MHz, 850 V, 100:1

Maximum pulse peak voltage as a function of the RMS voltage

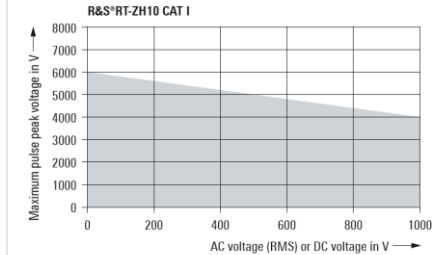

Power Electronics

RT-ZCxx Current Probes

- 1 mA to 2000 A
- Bandwidth up to 120 MHz
- BNC Interface or Rohde & Schwarz Probe Interface
- Deskew manual or automatic with RT-ZF20
- Auto zero and degauss on the oscilloscope with B model
- Precise and sensitive

R&S®RT-ZC20B current probe with Rohde & Schwarz probe interface (100 MHz, 30 A (RMS)).



External power supply for up to four current probes.



Power Electronics

RT-ZCxx Current Probes

	RT-ZC02	RT-ZC03	RT-ZC05B	RT-ZC10	RT-ZC10B	RT-ZC15B	RT-ZC20	RT-ZC20B	RT-ZC30
Bandwith	20 kHz	100 kHz	2 MHz	10 MHz	10 MHz	50 MHz	100 MHz	100 MHz	120 MHz
Rise time	5 μ s	1 μ s	175 ns	35 ns	35 ns	7 ns	3.5 ns	3.5 ns	2.9 ns
Sensitivity	0.01 V/A – 0.001V/A	0.1 V/A	0.01 V/A	0.01 V/A	0.01 V/A	0.1 V/A	0.1 V/A	0.1 V/A	1 V/A
Max current (RMS)	\pm 200A / \pm 2000A	20 A	500 A	150 A	150 A	30 A	30 A	30 A	5 A
Noise	30/80 mA	2 mA	25 mA	25 mA	25 mA	2.5 mA	2.5 mA	2.5 mA	60 μ A
Power supply	9 V Battery	9 V Battery	Oscilloscope	RT-ZA13	Oscilloscope	Oscilloscope	RT-ZA13	Oscilloscope	RT-ZA13



Power Electronics

Power Rail Probe R&S®RT-ZPR20/40

- For RTM, RTA, RTE and RTO
- 2 GHz or 4 GHz, 1:1, 50kΩ, DC / AC...
- ± 850 mv with an offset of ± 60 V
- Very low noise($100 \mu\text{V}$)

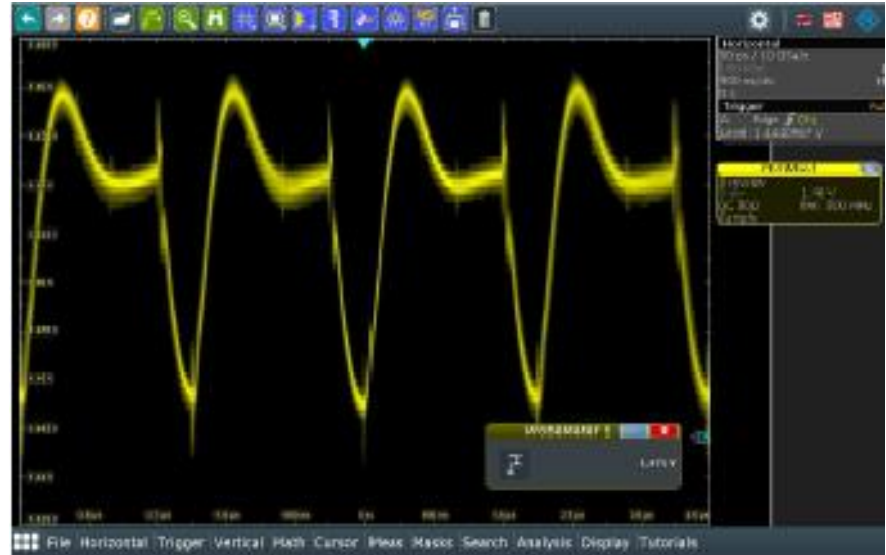

Power Electronics

Sondes Multi Channel Power Probe R&S®RT-ZVC02/04

- For RTE et RTO
- Power consumption in correlation with other analogue or digital signals
- ADC 18 bit
- 2 ou 4 Channels
- Range of 4.5 μ A à 10A
- Range of 1.88 V à 15 V
- 1 MHz Bandwith
- 5 MSa/s by canal



Merci

